

Genome Mining in *Streptomyces*. Discovery of an Unprecedented P450-Catalyzed Oxidative Rearrangement That Is the Final Step in the Biosynthesis of Pentalenolactone

Dongqing Zhu,^{†,§} Myung-Ji Seo,^{†,§} Haruo Ikeda,[‡] and David E. Cane^{*,†}

[†]Department of Chemistry, Box H, Brown University, Providence, Rhode Island 02912-9108, United States

[‡]Laboratory of Microbial Engineering, Kitasato Institute for Life Sciences, Kitasato University, 1-15-1 Kitasato, Sagamihara, Minami-ku, Kanagawa 252-0373, Japan

 Supporting Information

ABSTRACT: The *penM* and *pntM* genes from the pentalenolactone biosynthetic gene clusters of *Streptomyces exfoliatus* UC5319 and *Streptomyces arenae* TŪ469 were predicted to encode orthologous cytochrome P450s, CYP161C3 and CYP161C2, responsible for the final step in the biosynthesis of the sesquiterpenoid antibiotic pentalenolactone (**1**). Synthetic genes optimized for expression in *Escherichia coli* were used to obtain recombinant PenM and PntM, each carrying an N-terminal His₆-tag. Both proteins showed typical reduced-CO UV maxima at 450 nm, and each bound the predicted substrate, pentalenolactone F (**4**), with K_D values of 153 ± 14 and $126 \pm 11 \mu\text{M}$ for PenM and PntM, respectively, as determined by UV shift titrations. PenM and PntM both catalyzed the oxidative rearrangement of **4** to **1** when incubated in the presence of NADPH, spinach ferredoxin, ferredoxin reductase, and O₂. The steady-state kinetic parameters were $k_{\text{cat}} = 10.5 \pm 1.7 \text{ min}^{-1}$ and $K_m = 340 \pm 100 \mu\text{M}$ **4** for PenM and $k_{\text{cat}} = 8.8 \pm 0.9 \text{ min}^{-1}$ and $K_m = 430 \pm 100 \mu\text{M}$ **4** for PntM. The *in vivo* function of both gene products was confirmed by the finding that the corresponding deletion mutants *S. exfoliatus*/Δ*penM* ZD22 and *S. arenae*/Δ*pntM* ZD23 no longer produced pentalenolactone but accumulated the precursor pentalenolactone F. Complementation of each deletion mutant with either *penM* or *pntM* restored production of antibiotic **1**. Pentalenolactone was also produced by an engineered strain of *Streptomyces avermitilis* that had been complemented with *pntE*, *pntD*, and either *pntM* or *penM*, as well as the *S. avermitilis* electron-transport genes for ferredoxin and ferredoxin reductase, *fdxD* and *fprD*.

Pentalenolactone (**1**) is a widely occurring sesquiterpenoid antibiotic that has been isolated from more than 30 species of *Streptomyces*.¹ Pentalenolactone exerts its antibiotic action against both Gram-positive and Gram-negative bacteria as well as fungi and protozoa by reaction of the electrophilic epoxy lactone moiety with the active-site cysteine of glyceraldehyde-3-phosphate dehydrogenase, resulting in irreversible inactivation of this target glycolytic enzyme.² The committed step in the biosynthesis of pentalenolactone is the cyclization of farnesyl diphosphate (**2**, FPP) to the triquinane sesquiterpene pentalenene (**3**).³ We

have previously identified the responsible pentalenene synthase from *Streptomyces exfoliatus* UC5319 and reported the crystal structure of the recombinant enzyme.^{3b,3c} Experiments using chirally deuterated and tritiated samples of FPP established the detailed stereochemistry of the cyclization reaction itself, while feeding of labeled pentalenene to cultures of *S. exfoliatus* and analysis of the derived pentalenolactone confirmed the role of **1** as the parent hydrocarbon of the pentalenolactone family of metabolites.^{3a} Very recently, we isolated and sequenced two closely related 13-kb gene clusters from two different pentalenolactone producers, *S. exfoliatus* UC5319 and *Streptomyces arenae* TŪ469, which are responsible for the biosynthesis of this sesquiterpenoid antibiotic and have been designated as the *pen* and *pnt* clusters (Supporting Information (SI), Figure S1).⁴ Each biosynthetic gene cluster encodes 11 open reading frames (ORFs), with an average >90% mutual sequence similarity between each pair of orthologous gene products. We also identified and characterized the closely related *ptl* cluster from *Streptomyces avermitilis*, which we showed to be responsible for the biosynthesis of the recently discovered neopentalenolactone branch of the pentalenolactone family of metabolites.⁵ We have already assigned the biochemical function of eight of the key ORFs from each cluster, several of which are closely related to those of the *ptl* cluster, including five oxidative enzymes, four oxygenases (PenI/PntI, PenH/PntH, PenE/PntE, PenD/PntD), and the dehydrogenase (PenF/PntF) that together are responsible for the multistep oxidative conversion of pentalenene (**3**) to pentalenolactone F (**4**) (Scheme 1 and SI, Scheme S1).^{4a,5}

The only step in the biosynthesis that remains to be elucidated is the mechanism of the net oxidative rearrangement of pentalenolactone F (**4**) to pentalenolactone (**1**) itself. In fact, the only structural genes within the complete *pen* and *pnt* biosynthetic gene clusters whose functions have yet to be assigned are the orthologous genes *penM* and *pntM*. Each of these genes encodes a predicted cytochrome P450 of 398 amino acids, PenM and PntM, respectively, with 81% mutual sequence identity and 87% similarity.⁶

To confirm the predicted biochemical function of both PenM and PntM, synthetic genes corresponding to *penM* and *pntM* with codons optimized for expression in *Escherichia coli* were each inserted into the T7-based expression vector pET-28a(+),

Received: December 14, 2010

Published: February 1, 2011

Scheme 1

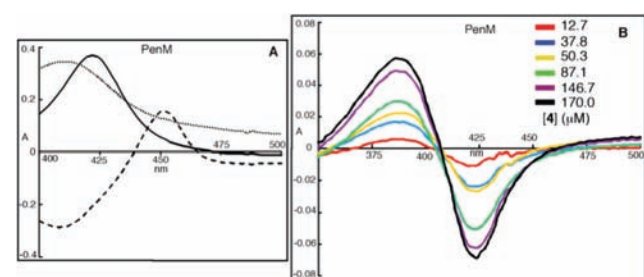
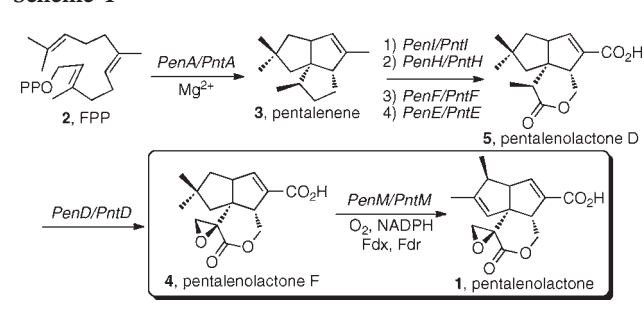

Figure 1. Characterization of PenM, CYP161C3. (A) Reduced CO difference spectra. Solid line, free, Fe^{3+} -PenM; dotted line, Fe^{2+} -PenM after $\text{Na}_2\text{S}_2\text{O}_4$ reduction; broken line, reduced CO complex. (B) Titration with pentalenolactone F (4), UV difference spectra.

and the corresponding plasmids pET28a-*penM* and pET28a-*pntM* were individually transformed into the expression host *E. coli* BL21(DE3). After induction with IPTG, the resulting recombinant PenM and PntM proteins, each carrying an N-terminal His₆-tag, were purified to >95% homogeneity by immobilized metal ion affinity chromatography on Ni^{2+} -NTA resin in yields of 21 and 27 mg/L of culture, respectively (SI, Figure S2). The purified His₆-tag-PenM had an M_D m/z 46 428 by ESI-MS (predicted 46 428 for P-Met protein), while His₆-tag-PntM had an M_D m/z 46 196 (predicted 46 195 for P-Met protein). High-resolution gel filtration chromatography established that both PenM and PntM are monomers.

The resting Fe^{3+} forms of both PenM and PntM each exhibited characteristic heme Soret bands at 420 nm (Figure 1 and SI, Figure S3). Upon treatment of each protein with sodium dithionite and exposure to CO, the reduced Fe^{2+} -CO difference spectra each showed a typical absorption maximum at 450 nm. Comparison of the P450 content with the concentration of each protein gave a calculated ratio of 1.05–1.10 P450 per subunit of protein. Titration of both PenM and PntM with pentalenolactone F (4) gave rise to the characteristic Type I P450 substrate-binding spectra, with a hypsochromic shift of the low-spin 420 nm absorption to a high-spin band at 390 nm. Analysis of the concentration dependence of the UV difference spectra gave calculated K_D values for 4 of 153 ± 14 and $126 \pm 11 \mu\text{M}$ for PenM and PntM, respectively.

To establish directly the biochemical function of both PenM and PntM, the individual purified recombinant proteins were incubated with pentalenolactone F (4) in the presence of spinach ferredoxin, spinach ferredoxin-NADP⁺ reductase, and a 25-fold molar excess of NADPH (Scheme 1). After 4 h incubation at 30 °C, followed by quenching with HCl and treatment of the organic extracts with trimethylsilyl-diazomethane (TMS-CH-

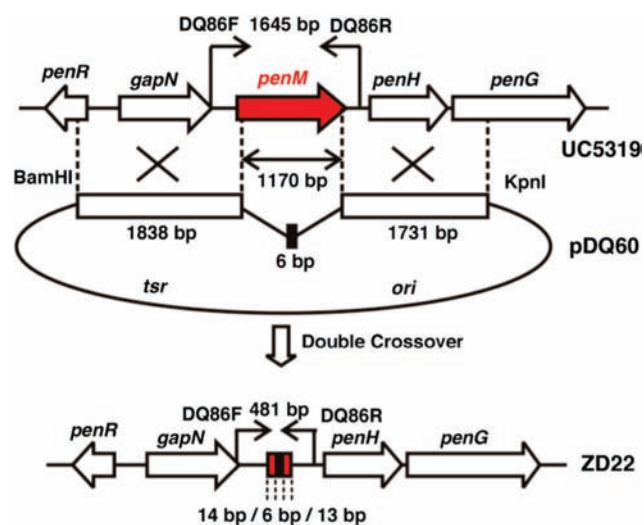

Figure 2. Construction of $\Delta penM$ deletion mutant *S. exfoliatus* ZD22.

N_2), GC-MS analysis indicated complete consumption of substrate 4 (absence of 4-Me, m/z 292) and formation of the pentalenolactone methyl ester (1-Me, m/z 290) (SI, Figure S4).⁷ The structure of the enzymatically generated 1-Me was established by direct comparison by capillary GC-MS with an authentic sample. The product 1-Me was accompanied by ~25% of a second, m/z 290 component of unknown structure whose GC-MS properties did not match those of authentic samples of any of the known isomers of pentalenolactone in either retention time (t_R) or mass spectrum. The steady-state kinetic parameters of both P450-catalyzed reactions were established by a series of 10 min incubations with PenM or PntM over a range of concentrations of 4 from 72 to 860 μM , followed by calibrated GC-MS analysis of the resulting 1-Me, giving $k_{\text{cat}} = 10.5 \pm 1.7 \text{ min}^{-1}$ and $K_m = 340 \pm 100 \mu\text{M}$ 4 for PenM and $k_{\text{cat}} = 8.8 \pm 0.9 \text{ min}^{-1}$ and $K_m = 430 \pm 100 \mu\text{M}$ 4 for PntM (SI, Figure S5).

We also investigated the *in vivo* role of the PenM and PntM P450s by using *Streptomyces* gene replacement to generate the corresponding in-frame deletion mutants, *S. exfoliatus*/ $\Delta penM$ ZD22 and *S. arenae*/ $\Delta pntM$ ZD23 (Figure 2 and SI, Figure S6).⁸ Thus, PCR was used to amplify 1860- and 1752-bp segments of DNA flanking the *penM* gene harbored in a 7-kb segment of the *pen* cluster.^{4a} The two fragments were religated and inserted into the vector pDQ44 to generate plasmid pDQ60, in which an 1170-bp internal segment of *penM* had been replaced by a 6-bp scar flanked by 14 bp from the original 5'-end of *penM* and 13 bp from the 3'-terminus of *penM*. Conjugation of plasmid pDQ60 into wild-type *S. exfoliatus* UC5319 and two successive rounds of homologous recombination gave the targeted *penM* deletion mutant ZD22, whose integrity was confirmed by PCR. In an analogous manner, PCR-targeted gene replacement was used to replace a 1563-bp segment of *pntM* with an 81-bp scar (Figure S6). Two successive rounds of homologous recombination then gave the targeted in-frame deletion mutant, *S. arenae*/ $\Delta pntM$ ZD23, using PCR to screen the exconjugants and to confirm the desired deletion.

Both wild-type *S. exfoliatus* UC5319 and *S. arenae* T \ddot{U} 469 as well as the corresponding deletion mutants *S. exfoliatus*/ $\Delta penM$ ZD22 and *S. arenae*/ $\Delta pntM$ ZD23 were cultivated in the appropriate liquid production media, and the resulting culture broths were assayed by GC-MS after methylation of the chloroform

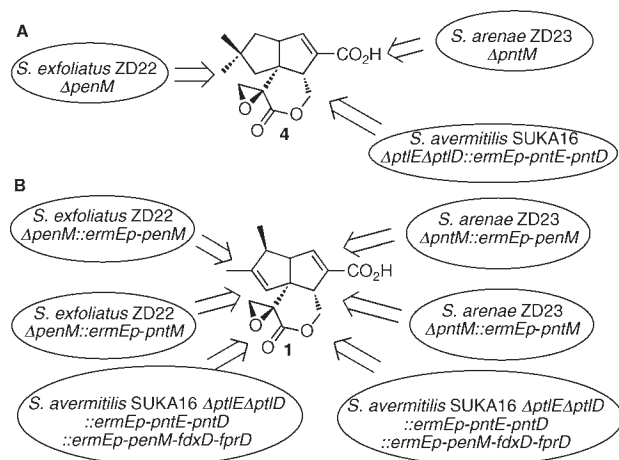
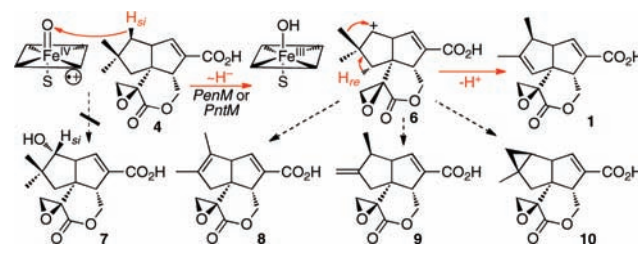

Figure 3. $\Delta penM$ and $\Delta pntM$ deletion mutants. (A) Accumulation of pentalenolactone F (**4**) by *S. exfoliatus* ZD22, *S. arenae* ZD23, and *S. avermitilis* SUKA16 $\Delta ptlE\Delta ptlD::ermEp-pntE-pntD$. (B) Complementation by *penM* or *pntM* restores production of pentalenolactone (**1**).

extracts with TMS- CHN_2 (Figure 3 and SI, Figure S7). While both wild-type strains produced, as expected, pentalenolactone methyl ester (**1-Me**, m/z 290), identified by direct comparison with an authentic sample, **1-Me** could not be detected in the methylated extracts of either P450- deletion mutant, ZD22 or ZD23. Instead, both *S. exfoliatus*/ $\Delta penM$ ZD22 and *S. arenae*/ $\Delta pntM$ ZD23 accumulated enhanced proportions of pentalenolactone F, analyzed as the corresponding methyl ester **4-Me** ($t_R = 12.82$ min, m/z 292), identical by direct GC-MS comparison with authentic **4-Me**. Interestingly, the proportion of pentalenolactone D (**5**)⁹ also decreased in cultures of both deletion mutants. Complementation of either *S. exfoliatus*/ $\Delta penM$ ZD22 or *S. arenae*/ $\Delta pntM$ ZD23 with *pntM* under control of the constitutive *ermE* promoter restored production of pentalenolactone (**1**), as established by GC-MS analysis and detection of enhanced levels of **1-Me** in the methylated extracts of each of the corresponding exconjugants (Figure 3 and SI, Figure S8). Similarly, conjugation of *penM* under control of *ermEp* into the corresponding ZD22 and ZD23 deletion mutants also restored production of pentalenolactone (**1**). Interestingly, all of the complemented strains also produced an additional unidentified m/z 290 component ($t_R = 13.44$ min) that also could be detected in extracts of both wild-type strains but was absent from both the *penM* and *pntM* deletion mutants and was identical to the m/z 290 side product of the *in vitro* incubation of recombinant PenM and PntM with pentalenolactone F. The structure of this additional product is under investigation.

We previously described the construction of an engineered strain, *S. avermitilis* SUKA16 $\Delta ptlE\Delta ptlD::ermEp-pntE-pntD$, that produces pentalenolactone F (**4**), along with the shunt metabolite 9,10-*epi*-pentalenolactone F (*epi*-**4**) (Figure 3A).^{4a} Complementation of this strain with either *penM* or *pntM* as well as the *S. avermitilis* ferredoxin and ferredoxin reductase genes, *fdxD* and *fprD*, all under control of the *ermE* promoter, led in both cases to production of pentalenolactone (**1**), as determined by GC-MS analysis of the methylated extracts (Figure 3B). In the absence of enhanced levels of the P450 electron transport proteins *fdxD* and *fprD*, the production of pentalenolactone (**1**) was significantly reduced (SI, Figure S9).¹⁰

Scheme 2



The P450-catalyzed oxidative rearrangement of pentalenolactone F (**4**) to pentalenolactone (**1**) has no biochemical precedent. Indeed, the vast majority of P450-catalyzed oxidations are simple oxygenations, such as hydroxylation of C–H bonds, epoxidation of alkenes, and heteroatom oxidation, or oxidative C–C bond cleavages and C–C bond-forming reactions, such as phenolic couplings.¹¹ Wagner–Meerwein-type carbocation rearrangements and elimination reactions are, of course, very common in nonoxidative terpene synthase-catalyzed transformations. Generation of the intermediate C-1 cation **6** from **4** presumably involves direct transfer of the H-1 *si* hydride^{3a} to a reactive ferryl iron–oxo species, or alternatively hydrogen atom abstraction of H-1 *si* followed by rapid electron transfer to the paired hydroxyl radical–iron species (Scheme 2). The transient, initially generated, highly oxidizing ferryl iron–oxo species, P450 compound I, has been implicated in the vast majority of P450-catalyzed reactions.^{11,12} P450-generated caged radical pair intermediates normally recombine to give the hydroxylated product with a rebound rate of $>10^{10}–10^{11} \text{ s}^{-1}$, with competing formation of cationic species representing at most only a very minor reaction channel.^{11b,13} The neopentyl cation intermediate **6** produced by oxidation of pentalenolactone F will undergo successive *syn* migration of the C-12 methyl group and coupled *anti* deprotonation with loss of H-3 *re* to give pentalenolactone (**1**).^{3a,14} Although we cannot definitively rule out an alternative radical rearrangement–hydrogen atom abstraction pathway for the formation of **1**, enzyme-catalyzed radical rearrangements are relatively rare, with the exception of P450-catalyzed reactions of artificial radical clock substrates such as cyclopropylmethylene derivatives^{11b,13} or the rearrangements catalyzed by corrinoid- or S-adenosyl methionine-dependent enzymes.¹⁵

The previously isolated (1*R*)-hydroxy shunt metabolite pentalenolactone H (**7**)¹⁶ is excluded as an intermediate or side product of the PenM- and PntM-catalyzed reactions since the configuration of the hydroxyl group of **7** and the retention of H-1 *si* are incompatible with the demonstrated loss of H-1 *si* from pentalenolactone F in the formation of **1**.^{3a} On the other hand, the isomeric products pentalenolactones A (**8**), B (**9**), and P (**10**), each of which has previously been isolated as a trace component in the culture extracts of pentalenolactone-producing *Streptomyces*,^{9,16} are presumably formed by competing deprotonation of **6** or the derived carbocationic intermediates of the dominant oxidative rearrangement pathway. Indeed, the formation of pentalenolactone P (**10**) suggests that the 1,2-methyl migration may involve a corner-protonated cyclopropane as an intermediate or transition state. None of these three very minor components could be detected, however, in the small-scale *in vitro* incubations of **4** with either PenM or PntM.

PenM and PntM have 84% and 89% sequence identity, respectively, to the SBI_10607 protein (CYP161C1) of

Streptomyces bingchenggensis.¹⁷ In fact, SBI_10607 is itself found within a predicted 11-ORF pentalenolactone biosynthetic gene cluster^{4a} and, therefore, is expected to catalyze the identical oxidative conversion of **4** to **1**. Neither PenM nor PntM has more than 50% identity to any other P450, as revealed by a BLAST search of the nonredundant protein database. The vast majority of the low similarity matches are to proteins that are either predicted hydroxylases or of altogether unknown function. For example, PntM has only 40% identity and 56% positive matches to the predicted 397-amino acid PimD protein (UniProt ID Q9EW92) that is believed to be responsible for an unspecified late-stage hydroxylation or epoxidation in the biosynthesis of the antifungal polyene antibiotic pimaricin.¹⁸ We anticipate that further mining of *Streptomyces* genomes will continue to unearth unusual and intriguing biochemical nuggets.

■ ASSOCIATED CONTENT

S Supporting Information. Experimental procedures, binding and kinetic data, and GC-MS analyses. This material is available free of charge via the Internet at <http://pubs.acs.org>.

■ AUTHOR INFORMATION

Corresponding Author

David_Cane@brown.edu

Author Contributions

[§]These authors contributed equally to this work.

■ ACKNOWLEDGMENT

This work was supported by NIH grant GM30301 (D.E.C.) and by a Grant-in-Aid for Scientific Research on Innovative Areas from MEXT Japan, from JSPS 20310122, and from the Institute for Fermentation, Osaka, Japan (H.I.).

■ REFERENCES

- (1) (a) Koe, B. K.; Sobin, B. A.; Celmer, W. D. *Antibiot. Annu.* **1957**, 672–675. (b) Martin, D. G.; Slomp, G.; Mizsak, S.; Duchamp, D. J.; Chidester, C. G. *Tetrahedron Lett.* **1970**, 4901–4904. (c) Keller-Schierlein, W.; Lemke, J.; Nyfeler, R.; Zähler, H. *Arch. Mikrobiol.* **1972**, *84*, 301–316. (d) Takahashi, S.; Takeuchi, M.; Arai, M.; Seto, H.; Otake, N. *J. Antibiot.* **1983**, *36*, 226–228. (e) Takeuchi, S.; Ogawa, Y.; Yonehara, H. *Tetrahedron Lett.* **1969**, 2737–2740.
- (2) (a) Hartmann, S.; Neeff, J.; Heer, U.; Mecke, D. *FEBS Lett.* **1978**, *93*, 339–342. (b) Cane, D. E.; Sohng, J.-K. *Arch. Biochem. Biophys.* **1989**, *270*, 50–61. (c) Cane, D. E.; Sohng, J.-K. *Biochemistry* **1994**, *33*, 6524–6530.
- (3) (a) Cane, D. E.; Oliver, J. S.; Harrison, P. H. M.; Abell, C.; Hubbard, B. R.; Kane, C. T.; Lattman, R. *J. Am. Chem. Soc.* **1990**, *112*, 4513–4524. (b) Cane, D. E.; Sohng, J.-K.; Lamberson, C. R.; Rudnicki, S. M.; Wu, Z.; Lloyd, M. D.; Oliver, J. S.; Hubbard, B. R. *Biochemistry* **1994**, *33*, 5846–5857. (c) Lesburg, C. A.; Zhai, G.; Cane, D. E.; Christianson, D. W. *Science* **1997**, *277*, 1820–1824.
- (4) (a) Seo, M.-J.; Zhu, D.; Endo, S.; Ikeda, H.; Cane, D. E. *Biochemistry* **2011**, doi: 10.1021/bi1019786. (b) The *pen* and *pnt* sequences have been deposited in GenBank with accession numbers HQ292066 and HQ292065.
- (5) (a) Ikeda, H.; Ishikawa, J.; Hanamoto, A.; Shinose, M.; Kikuchi, H.; Shiba, T.; Sakaki, Y.; Hattori, M.; Omura, S. *Nat. Biotechnol.* **2003**, *21*, 526–531. (b) Tetzlaff, C. N.; You, Z.; Cane, D. E.; Takamatsu, S.; Omura, S.; Ikeda, H. *Biochemistry* **2006**, *45*, 6179–6186. (c) Jiang, J.; Tetzlaff, C. N.; Takamatsu, S.; Iwatsuki, M.; Komatsu, M.; Ikeda, H.; Cane, D. E. *Biochemistry* **2009**, *48*, 6431–6440. (d) Quaderer, R.; Omura, S.; Ikeda, H.; Cane, D. E. *J. Am. Chem. Soc.* **2006**, *128*, 13036–13037. (e) You, Z.; Omura, S.; Ikeda, H.; Cane, D. E. *J. Am. Chem. Soc.* **2006**, *128*, 6566–6567. (f) You, Z.; Omura, S.; Ikeda, H.; Cane, D. E. *Arch. Biochem. Biophys.* **2007**, *459*, 233–240. (g) You, Z.; Omura, S.; Ikeda, H.; Cane, D. E.; Jogl, G. *J. Biol. Chem.* **2007**, *282*, 36552–36560.
- (6) Significantly, no homologue of the *penM* and *pntM* genes is found within the *S. avermitilis* neopentalenolactone *ptl* cluster.
- (7) Controls with boiled protein confirmed the dependence of the observed transformation on the recombinant P450, while no reaction was observed in the absence of either NADPH or added ferredoxin and ferredoxin reductase.
- (8) Gust, B.; Challis, G. L.; Fowler, K.; Kieser, T.; Chater, K. F. *Proc. Natl. Acad. Sci. U.S.A.* **2003**, *100*, 1541–1546.
- (9) Cane, D. E.; Sohng, J. K.; Williard, P. G. *J. Org. Chem.* **1992**, *57*, 844–852.
- (10) (a) Takamatsu, S.; Lin, X.; Nara, A.; Komatsu, M.; Cane, D. E.; Ikeda, H. *Microb. Biotechnol.* **2010**, DOI: 10.1111/j.1751-7915.2010.00209.x. (b) Takamatsu, S.; Xu, L.-H.; Fushinobu, S.; Shoun, H.; Komatsu, M.; Cane, D. E.; Ikeda, H. *J. Antibiot.* **2011**, *64*, 65–71.
- (11) (a) Ortiz de Montellano, P. R.; De Voss, J. J. In *Cytochrome P450: Structure, Mechanism and Biochemistry*, 3rd ed.; Ortiz de Montellano, P. R., Ed.; Kluwer Elsevier: New York, 2005; pp 183–245. (b) Ortiz de Montellano, P. R. *Chem. Rev.* **2010**, *110*, 932–948. (c) Although P450 compound I can also be represented as an Fe(V)=O species, which simplifies the formal electron bookkeeping in oxidation reactions, the overwhelming consensus of evidence is that the illustrated resonance form, with an Fe(IV)=O ferryl-oxo species liganded by a porphyrin cation radical, is a more accurate representation of the actual electronic state.
- (12) (a) Rittle, J.; Green, M. T. *Science* **2010**, *330*, 933–937. (b) Denisov, I. G.; Makris, T. M.; Sligar, S. G.; Schlichting, I. *Chem. Rev.* **2005**, *105*, 2253–2278. (c) Schlichting, I.; Berendzen, J.; Chu, K.; Stock, A. M.; Maves, S. A.; Benson, D. E.; Sweet, R. M.; Ringe, D.; Petsko, G. A.; Sligar, S. G. *Science* **2000**, *287*, 1615–1622.
- (13) (a) Newcomb, M.; Letadicbiadatti, F. H.; Chestney, D. L.; Roberts, E. S.; Hollenberg, P. F. *J. Am. Chem. Soc.* **1995**, *117*, 12085–12091. (b) Jiang, Y.; He, X.; Ortiz de Montellano, P. R. *Biochemistry* **2006**, *45*, 533–542.
- (14) (a) Cane, D. E.; Rossi, T.; Pachlatko, J. P. *Tetrahedron Lett.* **1979**, 3639–3642. (b) Cane, D. E.; Rossi, T.; Tillman, A. M.; Pachlatko, J. P. *J. Am. Chem. Soc.* **1981**, *103*, 1838–1843. (c) The fact that removal of H-3 *re* takes place on the face of the 2,2-dimethylcyclopentane ring of **4** opposite to that from which H-1 *si* is removed firmly rules out recapture of H-3 *re* by the transiently generated hydroxy-heme species.
- (15) Frey, P. A.; Reed, G. H. *Arch. Biochem. Biophys.* **2000**, *382*, 6–14.
- (16) (a) Seto, H.; Sasaki, T.; Uzawa, J.; Takeuchi, S.; Yonehara, H. *Tetrahedron Lett.* **1978**, 4411–4412. (b) Seto, H.; Sasaki, T.; Yonehara, H.; Takahashi, S.; Takeuchi, M.; Kuwano, H.; Arai, M. *J. Antibiot.* **1984**, *37*, 1076–1078.
- (17) (a) Wang, X. J.; Yan, Y. J.; Zhang, B.; An, J.; Wang, J. J.; Tian, J.; Jiang, L.; Chen, Y. H.; Huang, S. X.; Yin, M.; Zhang, J.; Gao, A. L.; Liu, C. X.; Zhu, Z. X.; Xiang, W. S. *J. Bacteriol.* **2010**, *192*, 4526–4527. (b) Cf. <http://drnelson.uthsc.edu/biblioE.html>.
- (18) Aparicio, J. F.; Fouces, R.; Mendes, M. V.; Olivera, N.; Martin, J. F. *Chem. Biol.* **2000**, *7*, 895–905.